

Owner's Manual & Installation Guide

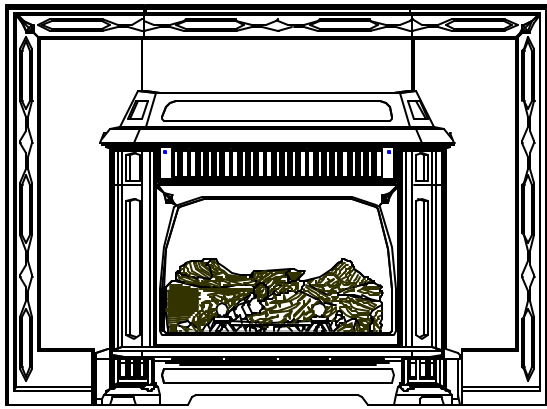

for the **Windsor Bay** (8830) GAS-FIRED DIRECT VENT HEATER



We recommend that our products be installed and serviced by professionals who are certified in the U.S. by NFI (National Fireplace Institute).

www.nficertified.org

READ THIS OWNER'S MANUAL

Operate and maintain this gas heater according to this instruction manual.

Read This Manual In Its Entirety.

WARNING: If the information in these instructions is not followed exactly, a fire or explosion may result causing property damage, personal injury or loss of life.

Do not store or use gasoline or other flammable vapors and liquids in the vicinity of this or any other appliance.

WHAT TO DO IF YOU SMELL GAS:

- Do not try to light any appliance.
- Do not touch electrical switches; do not use the phone in your building.
- Immediately call your gas supplier from a Neighbor's phone. Follow your gas suppliers instructions.
- If you cannot reach your gas supplier, call the fire department.

A qualified installer, service agency or gas supplier must perform installation and service.

AVERTISSEMENT: Assurez-vous de bien suivre les instructions donné dans cette notice pour réduire au minimum le risque d'incendie ou pour éviter tout dommage matériel, toute blessure ou la mort.

Ne pas entresposer ni utiliser d'essence ni d'autre vaperurs ou liquides inflammables dans le voisinage de cet appareil ou de tout autre appareil.

QUE FAIRE SI VOUS SENTEZ UNE ODEUR

DE GAZ:

- Ne pas tenter d'allumer d'appareil.
- Ne touchez à aucun interrupteur. Ne pas vous servir des téléphones se trouvant dans le bâtiment où vous vous trouvez.
- Appelez immédiatement votre fournisseur de gaz depuis un voisin. Suivez les instructions du fournisseur.
- Si vous ne pouvez rejoindre le fournisseur de gaz, appelez le service des incendies.

L'installation et service doit être exécuté par un qualifié installer, agence de service ou le fournisseur de gaz.

6400-40435
Model #8830
05-22-03



INFORMATION SHEET

Record, on this page, all relevant information concerning the purchase, installation, and maintenance of your WINDSOR BAY Gas-Fired Direct Vent heater. This information will facilitate servicing, purchase of replacement parts, and warranty claims (if necessary). Keep your original receipt in a safe place as proof of purchase.

Serial Number: _____

Fuel type (check one) _____ Natural Gas _____ Liquid Propane

Sold by: _____

Phone: _____ Date of Purchase: _____

Installed by: _____

Phone: _____ Date of Installation: _____

Gas Supplier: _____

Phone: _____

Read this Owner's Manual before installing or operating the WINDSOR BAY heater. Retain this manual for future reference.

SERVICE RECORD

Date	Who Performed Work	Work Performed	Notes:

WHAT
Firebox Cleaning.....
Glass Cleaning.....

WHEN
annually
as needed

WHAT
Door Gasket.....

WHEN
Replacement as needed

Introduction

Congratulations on your purchase of a Windsor Bay Gas-Fired Direct Vent heater. The Windsor Bay incorporates the latest in energy and gas technology, which will provide you with clean, efficient heat for years to come. The combination of natural stone and cast iron gives the Windsor Bay years of attractive looks and allows for durable performance that can be maintained with minimal care.

The Windsor Bay will provide you with years of practical and convenient service. However, as with any gas appliance, the unit must be properly and safely installed and maintained by qualified service personnel to ensure safe and trouble-free operation.

Your Windsor Bay is equipped with a standard pilot which:

1. generates a milli-volt signal that powers the wall-mounted thermostat and;
2. lights the main burner when the thermostat calls for heat.

This unit is equipped with an On/Off/T'STAT switch and a variable output control. The variable output control is located on the gas control valve. It allows you to vary the heat output, along with the flame height to suit personal taste. Heat output can be reduced {set to "LOW"} during the Fall and Spring, when the need for heat is reduced and increased {set to "HIGH"} during Winter months, when the need for heat is the greatest.

A wall-mounted thermostat is provided by HearthStone. Regardless of how you set the variable output control, when the optional thermostat has been installed and the

On/Off/T'STAT switch is set to "T'STAT", the wall-mounted thermostat will control the on/off cycling of the unit. At any time, you can override the thermostat with the On/Off/T'STAT switch by setting it to "ON" or "OFF".

The Unit is equipped with a two speed blower fan, which turns on and off independently of the burner flames. When the HIGH/OFF/LO switch, which allows you to turn the fan on or off and control the speed of the fan to suit your needs, is set to "High" or "Lo", the fan will automatically turn on when the stove is hot and cycle off when the unit is no longer hot.

Also available are two different optional remote controls. Both of the remote controls are capable of turning the unit on and off. One of the optional remotes also allows you to control the temperature of the stove from anywhere in the vicinity of the unit. If "ON" & "OFF" are the only controls required, Kit # 90-56912 can be used. If you would like to control the temperature via the remote control, use Kit # 90-56914.

READ THIS OWNER'S MANUAL

Operate and maintain this gas heater according to the instructions in this manual. Read this manual in its entirety. This manual has two sections, the first section is for the *OPERATOR*, and the second section is for the *QUALIFIED SERVICE PERSONNEL* only.

HEATER MUST BE INSTALLED AND MAINTAINED BY QUALIFIED SERVICE PERSONNEL

Verify the gas connections and venting systems with requirements of local, regional or national installation codes. Qualified service personnel must inspect the gas heater before use and at least annually.

TABLE OF CONTENTS

READ THIS OWNER’S MANUAL.....	1
INTRODUCTION	4
OWNER’S INFORMATION	5
SAFETY INFORMATION	5
SPECIFICATIONS:	8
ROUTINE MAINTENANCE AND CARE	11
INSTALLER’S INFORMATION	11
UNPACK AND INSPECT FOR DAMAGE	12
VENTING COMPONENTS & CONFIGURATION	14
ELECTRICAL CONNECTIONS	17
GAS SUPPLY & CONNECTIONS.....	20
ASSEMBLING THE UNIT.....	22
LOG PLACEMENT	26
LIGHTING THE UNIT FOR THE FIRST TIME	28
INITIAL ADJUSTMENTS	29
MAINTENANCE AND CARE.....	31
PARTS LISTS	33
LIMITED WARRANTIES	39

Owner’s Information

Safety Information

Your Windsor Bay is a very attractive and extremely efficient, utilizing today’s best technologies. By following a few simple safety precautions and by performing minimal maintenance, the unit will remain appealing while providing years of quality performance.

The installation must conform to local codes or, in the absence of local codes, the current

National Fuel Gas Code, ANSI Z223.1 (NFPA 54) or CAN/CGA B149 Installation Code. (*Installer l’appareil selon les codes ou règlements locaux, ou, en l’absence de tels règlements, selon les Codes d’installation CAN/CGA B149.*)

Do not use this appliance if any part has been under water. Immediately call a qualified service technician to inspect the heater and to replace any part of the control system and gas control that has been under water. (*Ne pas se servir de cet appareil s’il a été plongé dans l’eau, complètement ou en partie. Appeler un technicien qualifié pour inspecter l’appareil et remplacer toute partie du système de contrôle et toute commande qui ont été plongés dans l’eau.*)

During the first few hours of operation the appliance may produce a slight smoke and/or odor. This is normal during the first several burns. During the initial burn, open a window(s) to assist in the removal of the smoke/odor. If the logs appear to smoke, turn the heater off and call a qualified service technician.

The appliance and its individual shutoff valve must be disconnected from the gas supply piping system during any pressure testing of that system at test pressures in excess of ½ psig. (3.5k Pa). The appliance must be isolated from the gas supply piping system by closing its individual manual shutoff valve during any pressure testing of the gas supply piping system at test pressures equal to or less than ½ psig (3.5k Pa).

FIRE HAZARD

Do not store or use gasoline or other flammable vapors or liquids in the vicinity of this appliance. The Windsor Bay should be located out of traffic and away from furniture, draperies, clothing, and flammable material.

SHOCK HAZARD

This appliance is equipped with a three-prong (grounding) plug for protection against shock hazard and should be plugged directly into a properly grounded three-prong receptacle. Do not cut or remove the grounding prong from the plug.

MUST BE VENTED TO THE OUTSIDE

Never vent the gas heater to other rooms or buildings.

! WARNING:

This gas appliance must not be connected to a chimney flue serving a separate solid-fuel burning appliance.

SERVICE CAUTION

If you believe your Windsor Bay is not, in any way, performing properly, immediately discontinue operation until the unit has been inspected and approved by qualified service personnel. Prior to servicing the unit, turn the valve control knob clockwise to "OFF". The unit should be cool prior to servicing and cleaning. Any safety screen, guard, or component removed during servicing should be replaced prior to operation. Use of any components not supplied by HearthStone on the stove voids all warranties. **Do not substitute components.**

HOT SURFACES

Certain exposed surfaces of the Windsor Bay will reach high temperatures during normal operation. Clearances to combustibles must be maintained, as specified in the "Clearances To Combustibles" section of this manual.

Due to high temperatures the appliance should be located out of traffic and away from furniture, draperies, clothing and flammable materials. Children and adults

should be alerted to the hazards of high surface temperatures and should stay away to avoid burns to skin or clothing ignition. Young children should be carefully supervised when in the same room as the appliance. Clothing or other flammable material should not be placed on or near the appliance. *(Surveille les enfants. Garder les vêtements, les meubles, l'essence ou autres liquides à vapeur inflammables lin de l'appareil.)* Clean the area around, under, and behind the unit on a regular basis to prevent the accumulation of dust and lint.

NEVER BURN PAPER, WOOD, OR OTHER MATERIALS

This gas heater is designed to burn either natural gas (NG) or liquid propane (LP). Never burn any fuel that was not intended for use.

DO NOT LIGHT PILOT OR MAIN BURNERS BY HAND

The standing pilot light equipped with this gas heater is lit by using a piezoelectric spark generator, as described in the How To Turn The Unit On & Off section of this manual. Never attempt lighting the pilot or main burners by hand (with a match or lighter). After repeated attempts, if the pilot light fails to light, discontinue operation, turn off the gas control valve, and immediately contact qualified service personnel for assistance.

! **WARNING: DO NOT OPERATE THE APPLIANCE WITH THE FRONT GLASS REMOVED, CRACKED OR BROKEN. REPLACEMENT OF GLASS SHOULD BE DONE BY A LICENSED OR QUALIFIED SERVICE PERSON. ONLY OPEN FRONT FOR ROUTINE SERVICE. DO NOT SLAM OR STRIKE GLASS.**

CERAMIC FIBER LOG SAFETY INFORMATION

If the decorative ceramic log material supplied with the Windsor Bay is damaged or missing, it must be replaced with the same, approved replacement parts supplied by the manufacturer. These components affect the combustion quality and safety of the heater. Do not replace fiber ceramic logs with unapproved ceramic logs or any other material.

Always wear gloves and safety goggles while handling the log set and ember strip.

Caution

A reverse flue condition may occur if the venting is not attached correctly, or if the unit is lit before the glass front is properly secured. This condition may damage the unit.

Certified for use by:

Board of State Examiners of Plumbers and Gasfitters
100 Cambridge Street, Room 1511
Boston, Massachusetts
02202

SPECIFICATIONS:

**LISTED: DIRECT VENT
GAS HEATER**
Listed: DV Gas Heater
Model: Windsor Bay
 Direct Vent Insert Room
 Heater
Testing Agency: Intertek
 Testing Services NA Inc.
 (ITS)
Tested to: ANSI Z21.88-
 1998, CSA 2.33-M98,

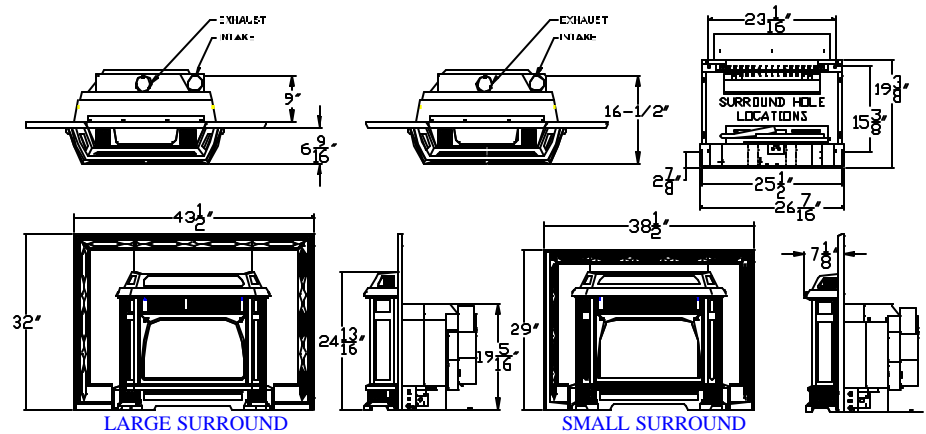
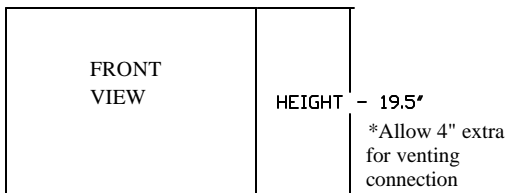
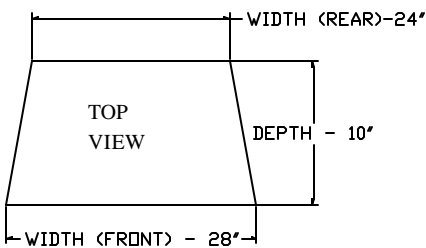

Figure 1: Windsor Bay Dimensions

	NG	LP
Input rating (Btu/hr) 0-2000ft	32,000	32,000
Maximum output (Btu/hr) 0-2000ft	24,000	24,500
Minimum input rating (Btu/hr)	20,000	26,000
Orifice size DMS 0-2000ft	46	56
Man. pressure- HI setting (in.w.c./kPa)	3.5/0.87	10.0/2.48
Man. pressure- LO setting (in.w.c./kPa)	1.6/0.42	6.4/1.59
Inlet pressure-HI (in.w.c./kPa.)	10.5/2.6	14.0/3.47
Inlet pressure-Lo (in.w.c./kPa)	5.0/1.24	11.0/2.88



Fireplace Dimensions

Fireplace Dimensions: Minimum Maximum

Width: 28" 42"

Height: 20" 31"

Depth: 10" >15"

*Allow 4" extra
for venting
connection

LIGHTING INSTRUCTIONS

NOTE: The gas control knobs and the piezo ignitor are located in the lower right side door.

1. STOP! Read the What To Do If You Smell Gas! Warning (on the cover of this manual).
 2. Set the on/off/T'STAT switch or thermostat to the "OFF" position.
 3. Push in and turn gas control knob clockwise to "OFF". (*If not previously lit, the knob should be in this position.*)
 4. Wait (5) five minutes to clear out any gas. If you then smell gas, STOP! *Smell all around the appliance area for gas. Be sure to smell next to the floor because some gases are heavier than air and will settle on the floor. If you smell gas immediately follow the What To Do If You Smell Gas! warning on the cover of this Manual.* If you do not smell gas, proceed to the next step.
 5. Turn gas control knob counter-clockwise to "PILOT".
 6. Push in control knob all the way and hold in. Immediately light the pilot with the piezo lighter (push in and "click" the red piezoelectric spark ignitor button several times until lit). Continue to hold the control knob in for about 20 seconds after the pilot is lit. Release the knob and it will pop back out. Pilot should remain lit. If the pilot goes out, repeat the operation.
- If knob does not pop out when released, stop, shut off the gas supply to the heater and immediately call a qualified service technician or gas supplier.
 - If the pilot will not stay lit after several tries, turn the gas control knob "OFF"

and call a qualified service technician or gas supplier.

7. After the pilot lights, turn gas control knob counter-clockwise to "ON".
8. If the ON/OFF/T'STAT switch is set to "ON", the stove should now be lit. If the thermostat (or remote) has been installed, set the ON/OFF/T'STAT switch to "T'STAT" and turn the thermostat (or remote) to "ON". Then set the desired temperature.
9. Shut the gas control valve access door.

NOTE: When pressing/clicking the red piezoelectric spark ignition button to light the pilot, watch through the glass (front) of the unit. Click the red ignitor button until a flame is visible at the pilot. Once the pilot is lit, continue to press on the gas control knob for another 20 seconds, then release. Ascertain that the pilot is still lit by looking through the front glass. If lit, then turn the gas control knob fully counter-clockwise to the "ON" position. If the pilot fails to light, or if it went out due to a premature release of the gas control knob while pressed in the "PILOT" position, wait 60 seconds for the Interlock to release. Then repeat the lighting process as described in this section of the manual.

Once the pilot has been lit, the gas control knob has been turned to the "ON" position, and the ON/OFF/T'STAT switch has been turned to "ON", the main burners should light immediately. If you would like to use the thermostat and it has been installed, switch the ON/OFF/T'STAT switch to T'STAT. Turn the thermostat to "ON" and set it to a higher position so that it "calls" for heat in order to turn light the main burners (i.e. turns the unit on). Note that the thermostat controls the on/off cycling of the main burners, but the pilot remains lit regardless of the thermostat setting. The only way to turn the pilot off is to turn the gas control knob fully clockwise to the "OFF" position.

TO TURN OFF GAS TO APPLIANCE

1. Set the thermostat to the "OFF" position or turn the ON/OFF/T'STAT switch to the "OFF" position.
2. If shutting the unit off for the non-heating season, turn the gas control

knob fully clockwise to the "OFF" position. Do not force the knob to turn.

DAILY OPERATION

The Windsor Bay gas-fired heater is easily operated by the homeowner once installed and adjusted by a qualified service technician. The unit can be controlled automatically or manually. The unit is controlled manually by setting the ON/OFF/T'STAT switch (upper switch) in the "ON" position, the thermostat will not operate, and the main burner will stay on constantly. In the "OFF" position, only the pilot remains lit but the main burners and thermostat will not operate. The unit is controlled automatically via the wall-mounted thermostat by setting the switch to "T'STAT". By setting the thermostat to the desired room temperature, the unit will cycle on and off as requested by the room thermostat, supplied with your stove. By adjusting the variable output control, located on the gas control valve, the rate of heat output can be varied to meet the heating requirements of the season. Choosing a low flame setting will result in longer burn cycles at a reduced output, while choosing a high flame setting will result in a shorter, hotter burn cycle.

Through trial and error you can select the optimum flame size for your setting and application. During the summer, non-heating season, switch the wall thermostat and rocker switches to "OFF", and turn off the pilot. This will improve the overall efficiency of the unit as the heat from the pilot is not wanted in the summer. When putting the unit back into service follow the Lighting The Unit portion in the How To Turn The Unit On & Off section of this manual.

When the unit is first lit, especially when cool, it is normal to experience some condensation on the inside of the glass window. This condensation will burn off within the first few minutes of operation. If continuous condensation or water drips are noted from any part of the unit, immediately discontinue operation of the unit and contact a qualified service technician.

Routine Maintenance and Care

The Windsor Bay requires minimal routine maintenance and care. The unit should always be cool and off when being cleaned.

CLEANING

WARNING: Do not clean the unit when hot. The unit should receive regular cleaning on, under, and around the stove to prevent the buildup of dust and lint. The exterior surfaces of the unit can be cleaned using soap, water, and a soft cloth. **Do not** use abrasive or chemical cleaners and take care not to scratch the stones, glass or enamel finish (if so equipped) when cleaning the unit. The use of chemical wax based cleaners or polishes are not recommended due to the potential for discoloration or the enamel when the residue of the cleaners or polishes is exposed to heat.

FIREBOX, PILOT, & BURNER TUBES

The firebox, pilot & burner tubes should receive periodic cleaning to prevent the accumulation of dust, lint and debris. Regularly check to insure the area around the Windsor Bay is kept free and clear from combustible materials, gasoline, and other flammable vapors and liquids. Check that the flow of ventilation air is not obstructed.

Once a year the unit and its venting system should be inspected by qualified service personnel to ensure that it is clean, free of obstruction, safe, and in good working order. If service or maintenance is required, qualified service personnel should perform it.

Installer's Information

CODES

Adhere to all **local codes** or, in their absence, the latest edition of THE NATIONAL FUEL GAS CODE ANSI Z223.1 (NFPA 54) or CAN/CGA B149 Installation Code that can be obtained from:

AMERICAN NATIONAL STANDARDS INSTITUTE, INC.

1430 BROADWAY
NEW YORK, NY 10018

OR

NATIONAL FIRE PROTECTION ASSOCIATION, INC.

BATTERY MARCH PARK
QUINCY, MA 02269

The appliance when installed, must be electrically connected and grounded in accordance with local codes or, in the absence of local codes, with the current NFPA 70-National Electrical Code or CSA C22.1-Canadian Electric Code.

A manufactured home (mobile) OEM installation must conform with the Manufactured Home Construction and Safety Standard, Title 24 CFR, Part 3280 (U.S.) or Standard for Manufactured Home Installation, ANSI/NCBCS A225.1 or Standard for Gas Equipped Recreational Vehicles and mobile Housing, CSA Z240.4.CAN/SCA Z240 MH (Canada). *(Installer l'appareil selon les codes ou règlements locaux, ou, en l'absence de tels*

règlements, selon les Codes d'installation CAN/CGA-B149.)

ITEMS REQUIRED FOR INSTALLATION

- * External regulator (for propane/L.P.G. only)
- * Piping which complies with local codes
- * Pipe sealant approved for use with propane/L.P.G. (resistant to sulfur compounds)
- * Manual shutoff valve
- * Sediment trap
- * Tee joint
- * Pipe wrench
- * Phillips head screwdriver
- * Other parts as required by local code
- * Safety Glasses
- * Gloves

PACKING LIST

- 1-Windsor Bay Gas-Fired Heater
- 1-Surround Set (3 pcs.) (optional)
 - 1-Hardware Set
- 1-Accessory Box
 - 1-Thermostat with 40' wire
 - 1-Owners Manual
 - 1-Warranty Validation Form
 - 1-Top Center Stone
 - 1-Top Center Grill
 - 2-Embers
 - 1-Andiron
 - 1-Ember Screen
 - 6-Decorative Ceramic Fiber Logs
 - 1-Flex Gas Tube
 - 1-Restrictor Disc

UNPACKING AND INSPECTION

UNPACK AND INSPECT FOR DAMAGE

The Windsor Bay is packaged by the manufacturer to withstand shipment without damage. However, damage can occur during transit so take care to inspect for damage when unpacking and installing the unit. If

any damage or missing parts are detected, immediately contact your dealer.

Do not install or put into service a damaged or incomplete heater.

Within the accessory box is the top center stone, top center grill, thermostat, and thermostat wire. The location and installation instructions for these parts will follow the inspection for damage.

Unbolt and lift off the pallet and partially insert it into the fireplace, (with regards to the Clearances To Combustibles section of this manual).

Inspect the stove for visible and/or concealed damage. The unit should appear to be square and true. The stones should be whole and without cracks, chips, or breakage. The sheet metal parts should be smooth and free of bends and/or dents. If the heater is enameled, the enameled cast iron should be free of chips and/or cracks.

If visible or concealed damage is found or suspected, contact your local dealer for instructions. Refer to Figure 7 on page 23 for the next step. To open the firebox, remove the front grill, and the 4 screws holding on the front façade. Inspect the log for damage. It is important to wear safety goggles and gloves when handling the log set. If a damaged log is encountered, contact your local dealer for a replacement log. Put the log set aside. It will be installed later.

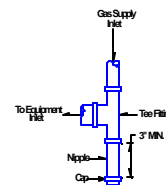

Sediment Trap

HEARTH REQUIREMENT/FLOOR PROTECTION

The Windsor Bay may be placed on a non-combustible surface or wood floor. For placement of the Windsor Bay on carpeting, vinyl tile or other combustible materials, the

appliance shall be installed on a metal or wood panel extending the full width and depth of the appliance. Installations must meet local codes.

Note: Some wood floor varnishes, stains, or polyurethanes may be affected by heat.

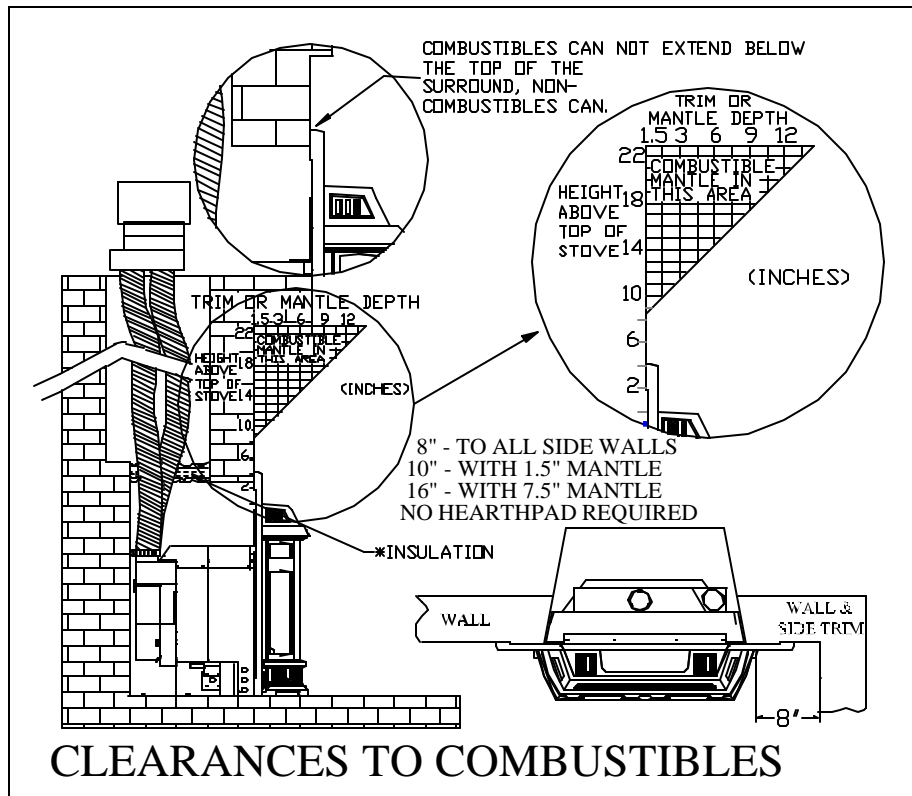

Figure 2: Clearances to Combustibles

CLEARANCE TO COMBUSTIBLES

Due to high surface temperatures, the unit should be located out of traffic and away from furniture and draperies. Clothing and other flammable material should not be placed on or near the heater. When positioning the unit always maintain adequate clearances around air openings into the combustion chamber and allow for adequate ventilation. Minimum clearances to combustibles must be maintained as shown in Figure 2.

NOTE: These clearances represent *minimum* distances in all cases, which, through testing in an independent laboratory to ANSI and CSA standards, will prevent fire or spontaneous combustion. We do not control the combustible materials exposed to heat by this product; therefore, an assessment must be made by the installer to prevent consequential damage of walls and flooring.

Venting Components & Configuration

The Windsor Bay cannot be vented jointly with any other solid fuel or gas appliance. The Windsor Bay must be vented directly to the outside of the building using a proper termination as listed below. The venting configuration is shown in figure 3. If the vent-air system is disassembled for any reason, reinstall per the instructions provided in the Assembling The Unit section of this manual.

CONFIGURATIONS FOR FIREPLACE INSTALLATIONS

1. Chimney Liner System*

1. Two Sections 3" Co-Linear Flex Liners (10ft Min./30ft Max.). Dura-Vent #2280

2. Chimney Liner Termination Kit (Includes Co-Linear to Co-Axial Termination and Flashing) Dura-Vent #923GK.
3. High Wind Termination Cap Dura-Vent #930.
4. High Temperature Silicone.
5. Four 3-1/2" Hose Clamps.

* Available through your local HearthStone dealer.

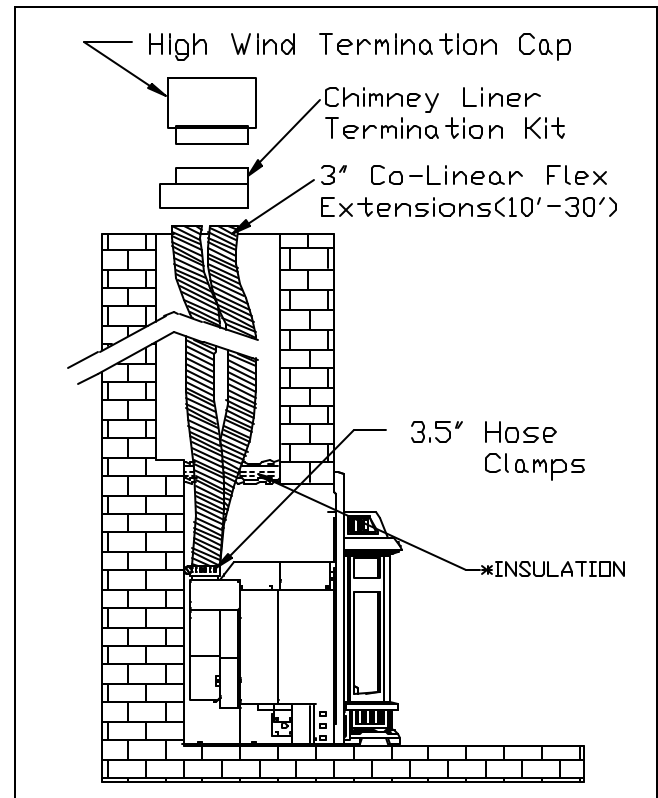

Figure 3: Venting Configuration

2. Using the existing chimney as an air inlet

The following installation procedure is not covered under the ANSI Z21.88 test method and product certification. Use of an existing chimney as an air intake must be specifically approved by your gas supplier and the local code Authority Having Jurisdiction

The chimney flue must be carefully sealed from the room environment. Fabricate a plate of non-combustible material and carefully fit it to the damper area with high temperature sealant.

This stove is certified for use with a coaxial venting system. ANSI Z21.88 standards state that the maximum leakage rate for the venting system is 32 SCFM @ .06" w.c. This leakage must be accounted for if you use the chimney for intake air.

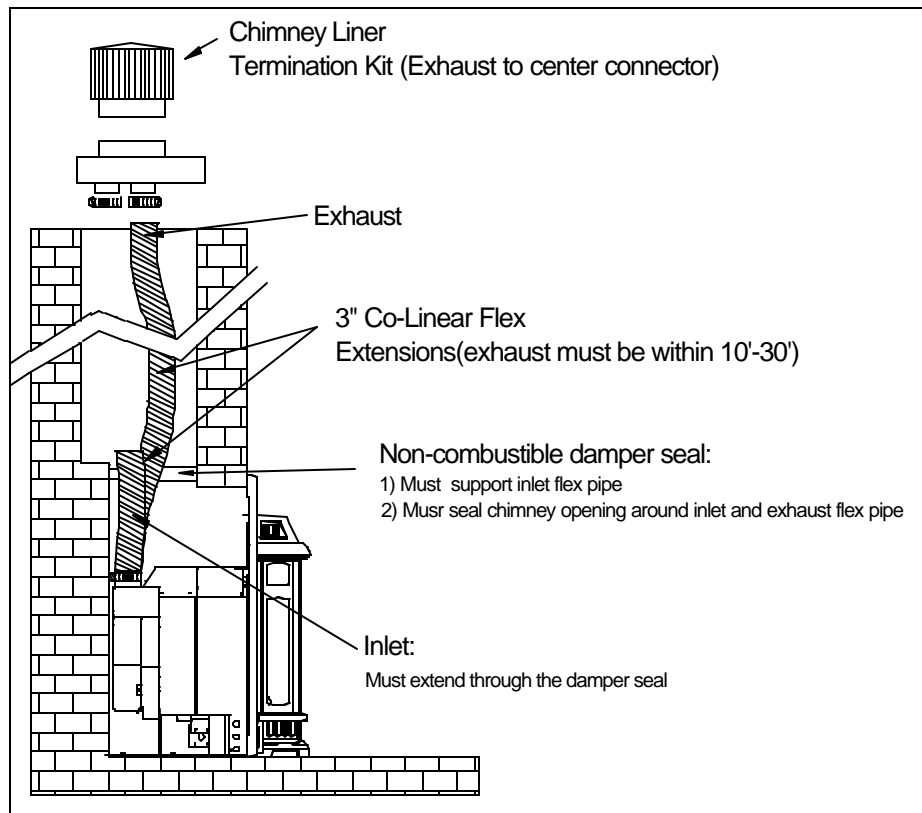

NOTE: All joints must be sealed. Leakage around the damper seal must be avoided.

WARNING: This installation may not work in a negative pressure environment, or if a seal cannot be attained. If sooting, ghosting of flame occurs, please check and repair leakage of chimney system.

Restrictor Disc

Your Windsor Bay has been supplied with a restrictor disc. This disc will provide excellent restriction for vertical runs exceeding 20 feet. If your vertical rise is less than 20 feet, do not use the restrictor.

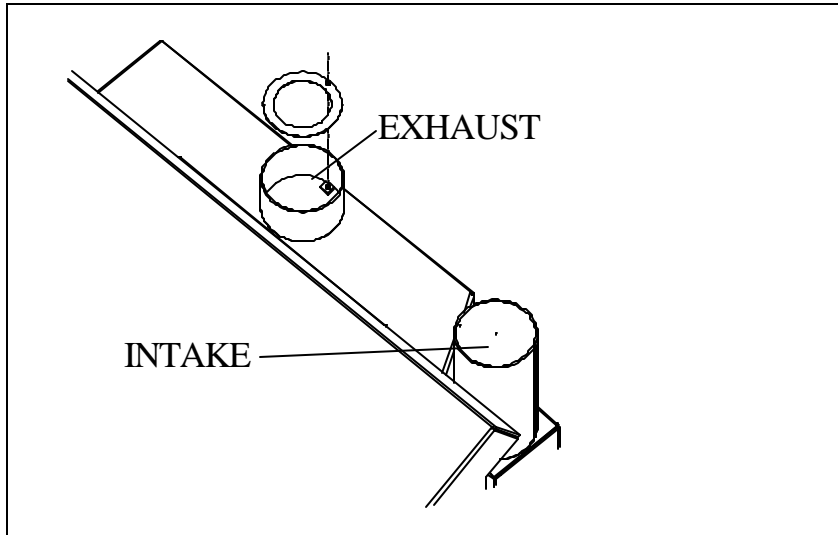

Figure 4: Restrictor Disc

Conditionally approved for purchased mobile home installation. This appliance may be installed in an aftermarket permanently located, manufactured (mobile) home, where permitted by local codes.

This appliance is only for use with the type of gas indicated on the rating plate. This appliance is not convertible for use with other gases, unless a certified kit is used, available through your local HearthStone dealer.

Cet appareil peut être installé dans un maison préfabriquée (mobile) déjà installée à demeure si les règlements locaux le permettent.

Cet appareil doit être utilisé uniquement avec les types de gas indiqués sur la plaque signalétique. Ne pas l'utiliser avec d'autres gas sauf si un kit de conversion certifié est installé

Electrical Connections

NOTE: OPEN VALVE DOOR ON THE RIGHT SIDE FOR ELECTRICAL AND GAS CONNECTIONS.

THERMOSTAT

The ON/OFF/T'STAT switch or wall mounted thermostat controls the Windsor Bay. We recommend installation of the thermostat for more comfortable performance, however you may still override the thermostat by setting the switch to "ON". The thermostat controls the unit by "calling for heat." The thermostat turns the unit on when the room is cold, and turns the unit off once the room is warmed sufficiently. The thermostat is controlled by a 750 millivolt DC two-wire circuit.

REMOTE CONTROL

There are two different optional remote controls. Both of the remote controls are capable of turning the unit on and off. One of the optional remotes also allows you to control the temperature of the stove, (in the same way the thermostat controls the heater), from anywhere in the vicinity of the unit. If "ON" & "OFF" are the only controls required, Kit #90-56912 can be used. If you would like to control the temperature via the remote control, use Kit #90-56914. Installation instructions are provided with the kits.

THERMOSTAT PLACEMENT

The thermostat should be placed in the same room or living space as the unit. Typically 5' (1.5m) off the floor and away from any influences that may cause the temperature in the vicinity of the thermostat to be unrepresentative of the room temperature in general. Such influences might include strong lighting, a heater vent from the

central heating system, or a nearby drafty window.

Placement of the thermostat on an inside wall rather than an outside wall is preferable. Do not place the thermostat directly behind or too close to the unit, otherwise heat from the unit will immediately satisfy the thermostat and turn the unit off.

THERMOSTAT WIRING

The thermostat wire from the unit to the thermostat can be surface mounted, routed under the floor, or through walls, etc. The thermostat should be connected to the unit using a maximum of 40' (12m) of insulated thermostat wire provided, but must not exceed 40' (12m) in length. Be sure to leave a small coil of wire behind the unit so that it can be moved out of position for servicing and cleaning.

ELECTRICAL GROUNDING

INSTRUCTIONS

This appliance is equipped with a three-prong (grounding) plug for your protection against shock hazard and should be plugged directly into a properly grounded three-prong receptacle. Do not cut or remove the grounding prong from this plug.

WIRING INSTRUCTIONS

The proper location of wire connections is shown following and in Figure 4. When making these connections, position the thermostat wire so it extends out the side surround panel towards the thermostat. (At the thermostat, the wires should be

connected to the two connection screws on the back of the thermostat per the instructions received with the thermostat). Take care not to over-tighten the connection

screws and not to damage the internal parts of the thermostat. Now attach the wires in their proper location on the fireplace, shown in Figure 5.

LOCATION OF WIRE CONNECTIONS:

Wire	Location	Label
Thermostat (2 wires)	1-Top Post on Valve	TH
	1-Bottom Post on Switch	T'STAT
Thermopile (2 wires)	1-Bottom Post	TP/TH
	1-Middle Post	TP

The proper location of wire connections is shown in Figure 5.

NOTICE: A qualified technician must connect the heater to the gas supply and leak test the unit before it is approved for use. Consult all local codes.

‡ **WARNING:** The unit must be installed and connected in accordance with local codes, or in the absence of local codes, with the most current edition of the National Fuel Gas Code ANSI Z223.1.

Wiring Diagram - Windsor Bay Fireplace Insert

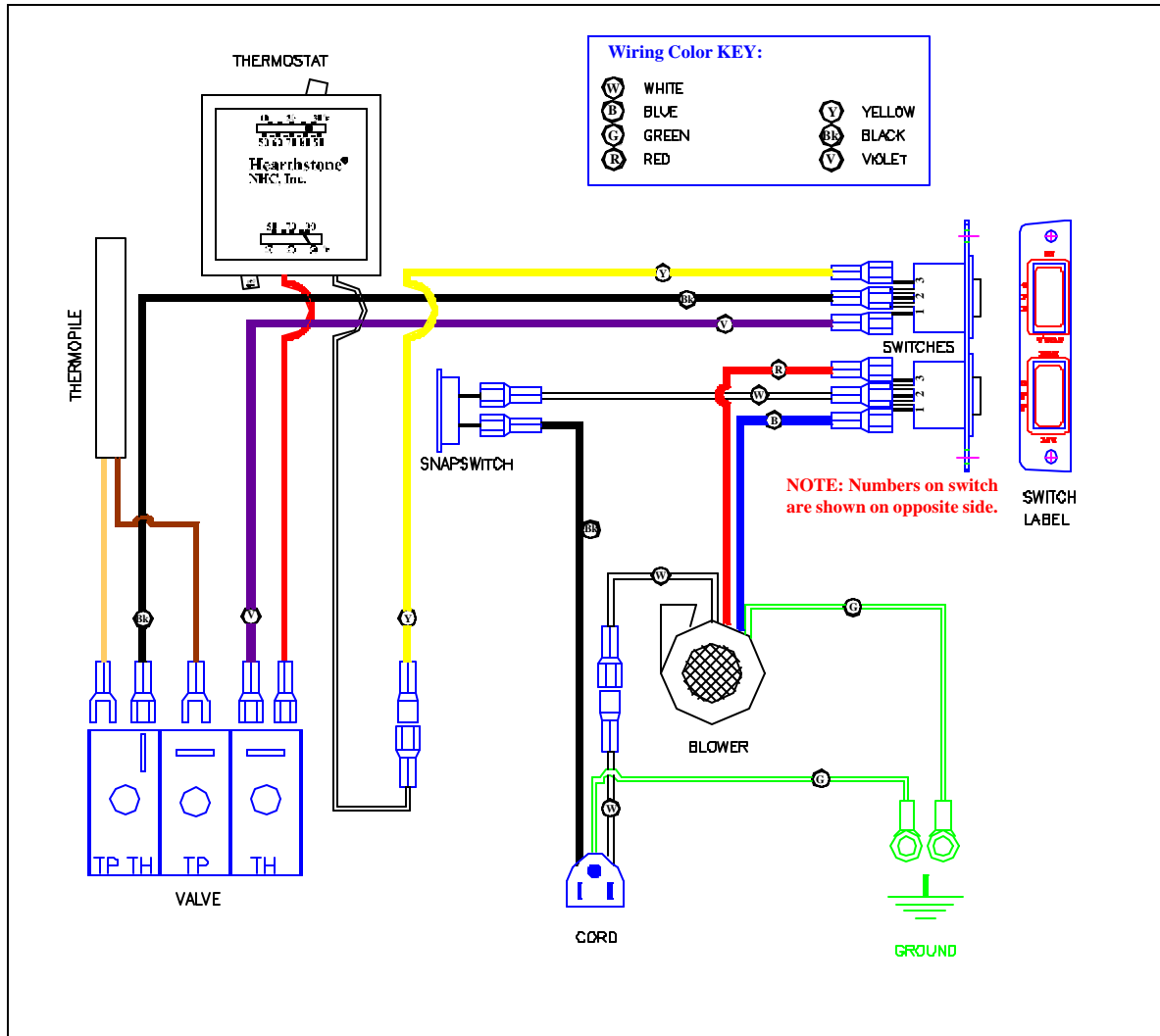

Figure 5: Wiring Diagram

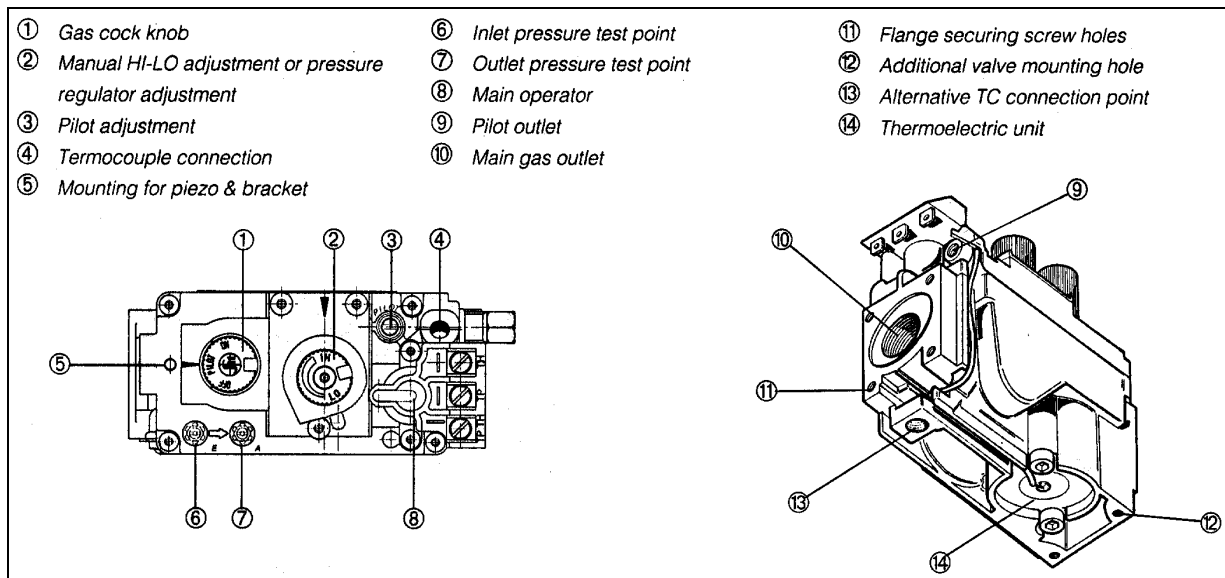

Figure 6

Gas Supply & Connections

NOTICE: A qualified technician must connect the heater to the gas supply and leak test the unit before it is approved for use. Consult all codes.

WARNING: The unit must be installed and connected in accordance with local codes, or in the absence of local codes, with the most current edition of the National Fuel Gas Code ANSI Z223.1 (NFPA 54) or CAN/CGA B149 Installation Code.

We recommend using new black iron or steel pipe only. Internally tinned copper tubing can be used in some areas when permitted by local codes. Only use pipe of 1/2" or greater diameter to allow full gas volume to heater, without undue loss of pressure. Excessive pressure loss will occur if the pipe is too small.

The gas supply line must include a manual shut-off valve and union so the unit can be disconnected for servicing. Also a sediment trap and a 1/8" N.P.T. plugged tapping must be installed upstream of the heater. The sediment trap is installed to prevent moisture and contaminants from passing through the pipe to the heater controls and burners. Failure to install a sediment trap could prevent the heater from operating reliably. The 1/8" N.P.T. plugged tapping is installed for the test gauge connection (immediately upstream of the gas supply connection). Damage to the valve caused by lack of a sediment trap will not be covered by the warranty.

We have supplied a 24" flexible stainless steel gas line for installation convenience and to avoid undue mechanical load on the valve. We recommend using the flexible line, but also refer to local code. The gas supply line connection is made to the flexible line in the lower rear right portion of the Windsor Bay. Apply a thread sealant to both male ends on the flexible gas line.

Thread one end directly into the valve and the other to a 3/8" connector on the gas line.

! **CAUTION: Check Gas Type!**

The gas supply must be the same as stated on the heater's rating plate (located on the unit). If the gas supply is different, **DO NOT INSTALL** the heater. Contact your dealer for the correct model or conversion kit.

GAS PRESSURE ADJUSTMENT

NOTE: A QUALIFIED TECHNICIAN MUST PERFORM THIS PROCEDURE!

The supply line pressure is tested to ensure it meets minimum pressure requirements, as listed in the Specifications sections of this manual, for the type of fuel in use (NG or LP).

The unit must be isolated from the gas supply piping system by closing its individual manual shutoff valve during any pressure testing of the gas supply piping system at test pressures equal to or less than 1/2 psig.

During tests in excess of 1/2 psig (14" w.c.), the heater must be disconnected from the gas supply system. Test by connecting a manometer to the supply line. Adjust the incoming pressure, if necessary, to meet the required supply line pressure.

Once connected to the gas supply, the gas inlet pressure and manifold gas pressure must be tested. The gas inlet tap (6) and manifold pressure tap (7) is located on the control valve (see Figure 6). Connect a manometer to the test points on the gas control valve.

NOTE: For installations from 0-1370 meters (0-4500ft), the orifice sizes (DMS) for natural and propane gas are 46 and 56 respectively. (*Cet appareil est équipé pour des altitudes comprises entre 0 et 4500 pieds (0-1370m) seulement.*) See data plate for additional information. For high altitude installations consult the local gas distributor or the authority having jurisdiction for proper rating methods. If the unit must be adjusted, the information sticker (provided with the high altitude kit) must be filled out completely and mounted to the unit per the instructions provided with the kit.

Assembling The Unit

You Will Need the Following to Complete the Installation:

- Surround Set (See Dimensions)
- Two – 3” Flex Liners (Dura-Vent #2280)
- Co-Linear Chimney Liner Termination Kit (Dura-Vent #923GK)
- High Wind Termination Cap (Dura-Vent #991)
- Four – 3.5” Hose Clamps
- Gas Hookup Equipment/Tools
- High Temperature Silicone
- Small Level
- Phillips Screwdriver
- Slotted Screwdriver or 5/16” Nut Driver
- Thread Sealant
- Open End Wrenches or Adjustable Wrench
- Permanent Marker
- Allen Wrench (supplied)

Before You Begin

Make sure the masonry fireplace and flue comply with the applicable codes and are in good condition. Repair any damage before installation of the Windsor Bay begins. Prepare a zero clearance (metal) fireplace by doing the following:

- Remove the damper, grate, and log set.
- If necessary, remove the smoke shelf, internal baffles, screen, masonry lining and doors. (see Fireplace Dimension requirements for on page 7)
- DO NOT remove any insulation or structural frame members.
- DO NOT remove or alter the metal sides, floor, doorframe, or face of the fireplace.

Install a 3/8” gas line, or an appropriate size to provide a sufficient gas supply to meet the maximum demand of the unit without undue loss of pressure, a gas shut-off valve, and a sediment trap before installing the insert. The gas line will enter the valve on the right side of the unit.

INSTALLATION OF THE CO-LINEAR PIPE

To complete the installation of the co-linear venting system, you will need the following components”

- Two Sections 3” Co-Linear Flex Extensions (10 ft min./30 ft max.). Dura-Vent #2280
 - Chimney Liner Termination Kit (includes Co-Linear to Co-Axial Termination and Flashing). Dura-Vent #923GK
 - High Wind Termination Cap. Dura-Vent #930
 - High Temperature Silicone.
 - Four 3-1/2” Hose Clamps.
- Mark each end of the flexible vent pipes “intake” with a permanent marker. Mark each end of the other flexible vent pipe “exhaust”.
- Apply the high temperature silicone to the top outer edge of both the intake and exhaust collars on the back of the unit. The exhaust adaptor is the collar in the center of the unit. The intake adaptor

collar extends further to the right of the stove (refer to Figure 1, on page 7). Slide a hose clamp over the ends of both flexible vent pipes. Place the flexible vent pipe marked “intake” onto the intake collar, place the flexible vent pipe marked “exhaust” onto the exhaust collar. Secure them to the collar adaptors by tightening the hose clamps with a slotted screwdriver or 5/16” nut driver.

- Repeat this process on the upper portion of the vent (flex pipes to co-linear to co-axial adaptor). **Important:** Make certain the pipe hooked to the exhaust on the stove hooks to the exhaust portion of the co-linear to co-axial adaptor. Be sure to meet all the manufacturers requirements when installing the adaptor and cap assembly. Follow the manufactures instructions when installing the same.
- The following guidelines must be observed when installing the vent pipes:
 - DO NOT crimp or rupture the vent pipes.
 - BOTH the exhaust and intake vent pipes must reline the entire length of the chimney. The exhaust and inlet vents must terminate above the top of the chimney using the appropriate vent termination components listed in these instructions.
 - DO NOT install the venting into a chimney serving another appliance, be it fossil fuel or solid fuel.

INSTALLING THE SURROUNDS/INSERT

You will need to determine which surround set you will need, the standard or the large using the following dimensions:

Standard Surround Set

Height: 29”

Width: 38.5”

Large Surround Set

Height: 32”

Width: 43.5”

Each surround set will have the following hardware:

4 – Phillips Panhead Bolts (joins surround side panels to surround top panel)

NOTE: The large surround set uses 6 Panhead screws to join the side surrounds to the top surrounds.

4 – Phillips Pan Hd. ¼-20 x 1-1/4” Bolts (joins assembled surround to insert)

2 – Phillips Roundhead Bolts (attaches switch plate to surround)

- Before installing the surround, locate the upper heat exchanger baffle on the top of the insert. Remove the front plate portion of this piece by removing the three Phillips screws located on the face of the heat exchange baffle. Set this piece aside for now, it will be put back on after the surround is installed.
- Attach the side surrounds to the top surround piece by attaching the four (or six) Phillips Panhead screws through the back of the surround pieces (two or three through each side, upper left and upper right).
- Place the surround set onto the face of the insert. Attach the top of the surround by turning two of the Phillips Panhead bolts through the upper holes in the surrounds. These will line up with speed nuts on the heater. Fasten the bottom of the surround to the heater by inserting the other two Phillips Panhead bolts through the lower holes on the surrounds. These bolts will line up with

- speed nuts located on the insert. (refer to Figure 7 for assembly).
- Slip the switch plate into position on the right side of the surround panel. Fasten it to the surround using the two Roundhead Phillips screws.
 - **WARNING:** Failure to position the parts in accordance with the Figures in this manual, or failure to use only parts specifically approved with this appliance may result in property damage or personal injury.
 - Place a level on top of the unit. Leg leveling bolts are located in the front and rear of the base plate. Adjust the rear leveling bolts now as they will not be accessible once the unit is fully inserted into the fireplace.
 - Push the unit as far into the fireplace as you can, leaving just enough room for the fan power cord to exit on the bottom right side, between the surround and fireplace.
 - Place the front plate (previously removed from the upper heat exchanger baffle) back into position on the face of the unit. Re-attach to the unit with the three Phillips screws.
- Before replacing the front façade, carefully unwrap and place the log set into the unit. Refer to Log Set information section of this manual for the precise positioning of the log.
 - Place the front façade back onto the insert, retaining it with the 4 Allen Flat Head bolts. Two of these bolts screw into threaded inserts while two screw into speed nuts.
 - Replace the front grill and retain it with the two Phillips screws.
 - Place the top grill into the top of the heater. Carefully set the top stone into the top grill.
 - Place a level on the top of the unit. Two leveling leg bolts are located in the front of the base plate. Use a wrench to turn these bolts up or down as necessary to level the unit. Note, leveling bolts are also located in the back of the base, but the insert must be pulled out of the fireplace to gain access to them.

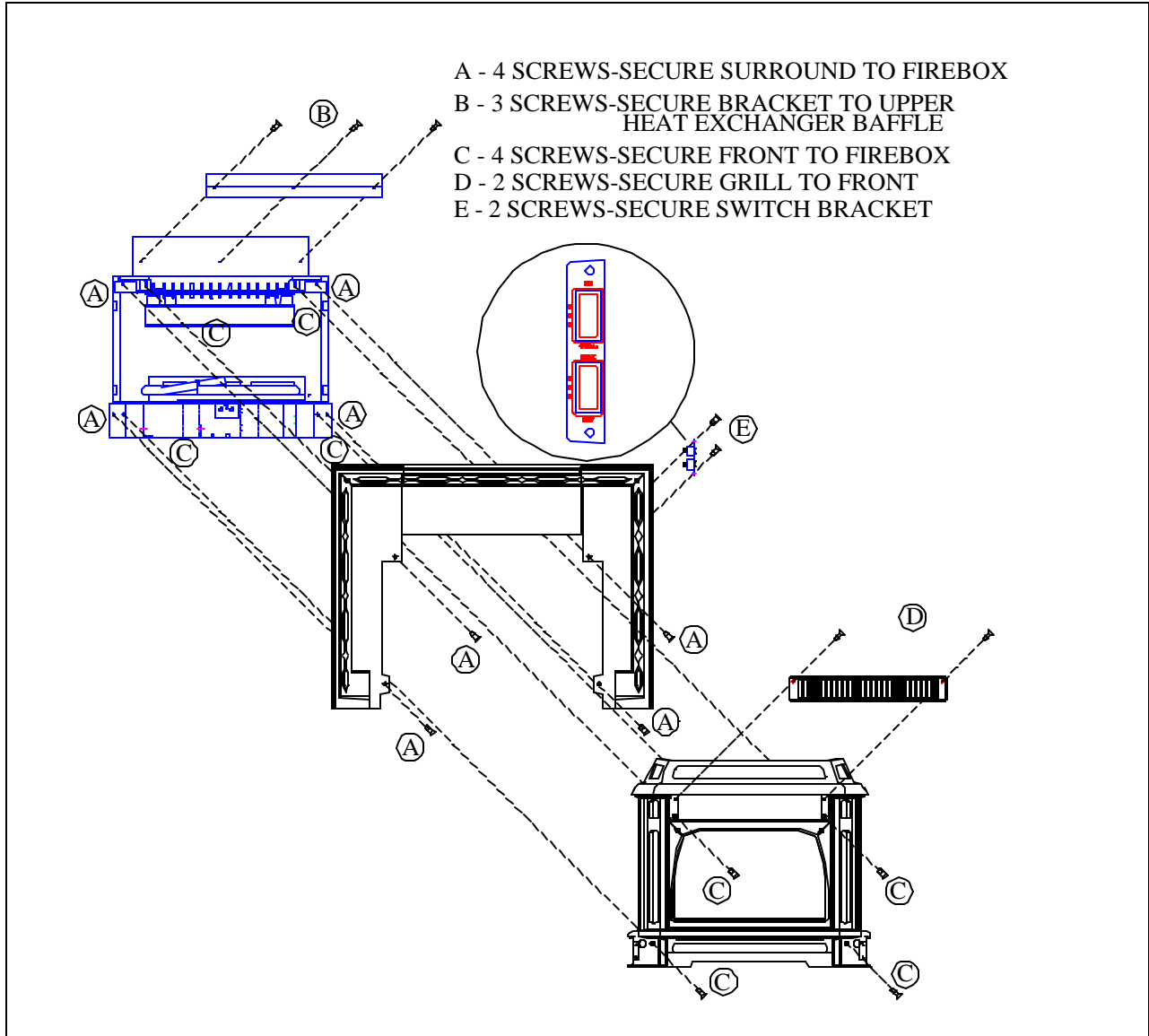

Figure 7: Assembly

Log Placement

CAUTION: Fragile! Handle log set with care. Always wear gloves and safety goggles while handling the log set.

Only the decorative ceramic fiber log set supplied with the unit should be placed in the firebox. Do not place any other ceramic logs, wood logs, or other materials in the firebox. If the log set is damaged or broken contact your dealer for replacement. The decorative ceramic fiber log set will last a long time, however, they will break if subjected to rough or improper handling. Exact positioning of the log set is required in order to obtain a pleasing flame pattern and efficient combustion. Incorrect log placement may cause carbon build-up; excess thermal stress on the log set and stove parts, reduced efficiency, and high levels of carbon monoxide. If the log set does not set into the firebox exactly as outlined, contact your dealer for assistance.

INSTALLATION OF THE LOG SET

(Refer to figures 8 & 9 for log set assembly)

NOTE: The rear and middle logs with “locator” posts should be on the right side of the firebox when installed.

1. The log set and an ember screen must be placed in the firebox at their precise location. Remove the front façade as described in the ‘Inspect For Damage’ section of this manual.
2. Remove the packaging material around the log set assembly. Be careful not to damage the log set when unpacking.
3. Using the ‘locator’ tabs on the bottom of the rear logs, position the rear logs on the ridge to the back of

the firebox near the base of the firebox.

4. Place the two middle logs with grooves over the two burner tubes. The face should be parallel to the leg of the burner tubes. Now the center log will fit over the ‘locator’ posts on both the rear and middle logs.
5. Position the front log in front of the burner tubes on the base of the firebox. Place the ember screen over the two burner tubes. It will fit tightly around the right middle log and in front of the left middle log.
6. Place the andiron support and andiron in the groove on the front log.
7. **NOTE** When installing the embers be sure to leave gaps throughout the burner. (This is important to allow for proper ignition of the burner tube) It is recommended to experiment with arranging of the embers to achieve a pleasing flame pattern. **Leave embers off the pilot to allow the pilot flame to ignite the ignition ports on the burner tube.** Open the two bags of embers and distribute the large embers evenly across the burner tubes, on top of the ember screen. Next, scatter the small embers throughout the burner to create a pleasant flame pattern, leaving gaps throughout the burner.
8. Close the stove. With an Allen wrench, replace the front façade by following the instructions as described in the Assembly Of The Unit section of this manual. Be sure to **evenly** draw the screws tight to the front of the firebox. Make sure the front is properly secured to the firebox before turning the unit on. Be careful not to chip the enamel when fastening the front.

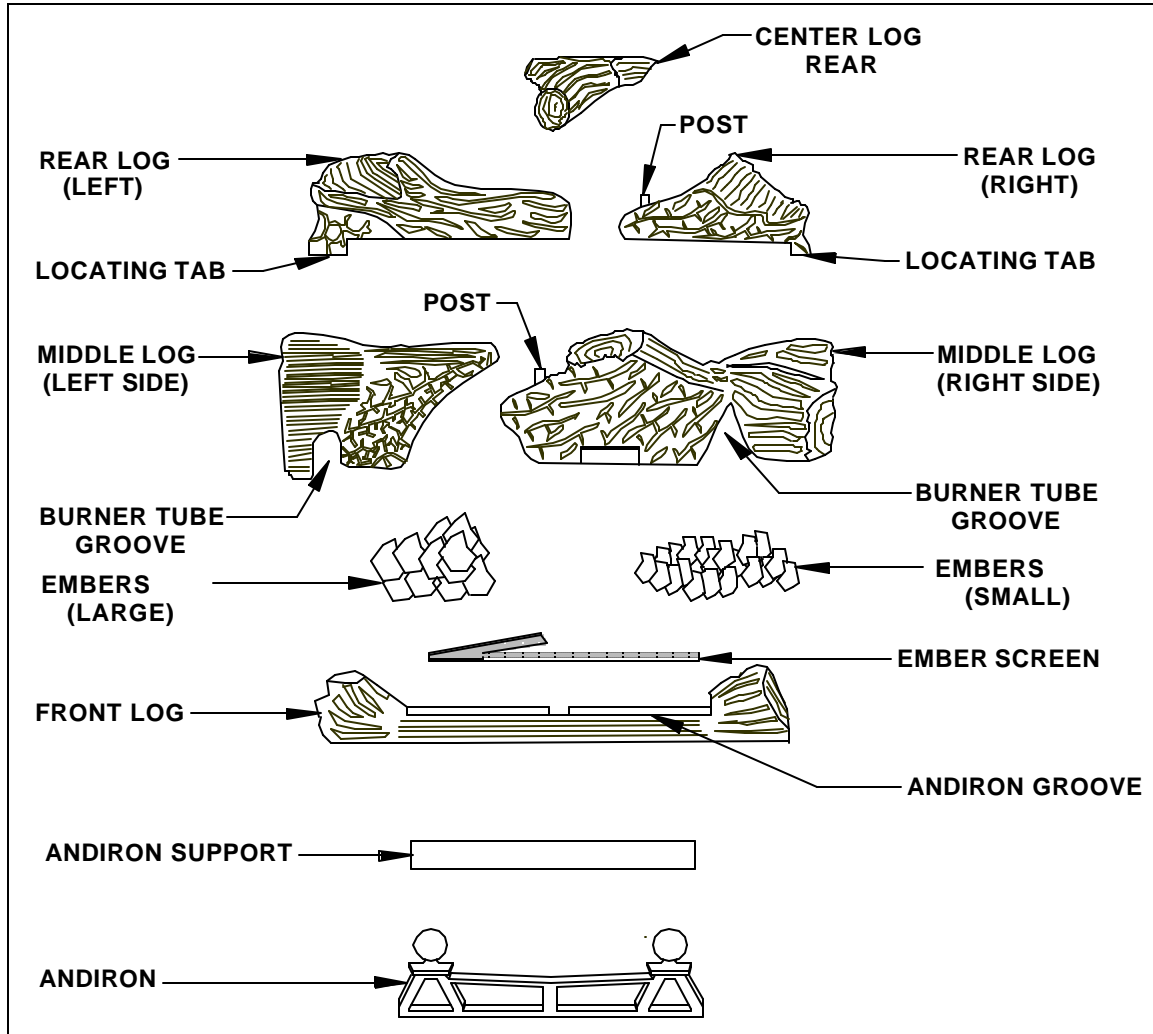

Figure 8: Log Set Assembly

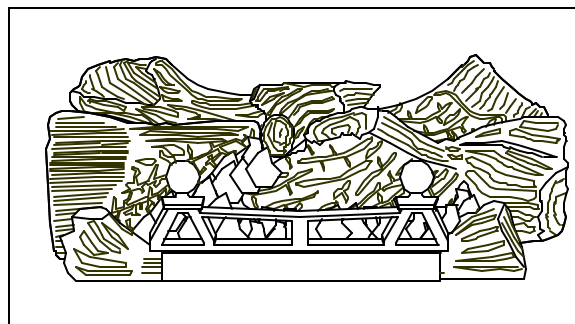

Figure 9: Assembled Log Set

REMOVAL OF THE LOG SET

To remove the log set, follow the Installation of Log Set instructions in the reverse order.

Lighting the Unit for the First Time

- | **WARNING:** If you do not follow these instructions exactly, a fire or explosion may result causing property damage, personal injury or loss of life.
- | **CAUTION:** Lighting the Windsor Bay for the first time and adjustments to the unit should be performed by qualified service personnel.

SMOKE AND FUMES WARNING

When lit for the first time, the Windsor Bay will emit some smoke and fumes. This is normal “off-gassing” of the paints and oils used in the manufacturing and assembly of the unit. Open windows to vent the room if necessary. The off gassing and fumes will subside after the first 10 to 20 minutes of operation.

ODORS AND IMPURITIES

A heater of this type may produce odors during heater operation due to impurities that may exist in the immediate area. Sources of impurities can be cleaning solvents, paint solvents, cigarettes, smoke, pet hair, dust, adhesives, new carpet, and/or textiles. Such odors will dissipate. However, opening a window or otherwise providing additional ventilation to the area can alleviate the condition. If any odor persists, contact your dealer or an authorized service technician.

PILOT LIGHT WARNING

The Windsor Bay has a piezoelectric spark igniter, (the red push button located next to the gas control valve behind the valve access door) which ignites the pilot light by means of a spark at the pilot light assembly. Do not attempt to light the unit with a match or by any means than the piezoelectric spark.

PREPARE FOR LIGHTING

Prepare for the lighting procedure by adjusting the thermostat (if equipped) to its lowest setting or OFF position. If the gas control knob is not in the OFF position, turn the knob fully clockwise to OFF. Locate the variable output control knob and turn it fully clockwise to the highest setting.

Prior to lighting the unit for the first time, wait 5 minutes to allow any residual gas within the unit to dissipate. Smell all around the appliance area for gas. Be sure to smell next to the floor because some gases are heavier than air and will settle on the floor. If you do not smell gas after this five-minute period, proceed with the lighting procedure. If you do smell gas, **DO NOT** proceed with the lighting procedure. Instead, **immediately refer to the What To Do If You Smell Gas Warning, on the cover of this manual.**

Initial Adjustments

Once the Windsor Bay has been set in place, connected and assembled as described in the Clearances To Combustibles, Venting Components & Configurations, Electrical Connections, And Gas Supply and Connections sections of this manual, the unit is almost ready to be lit for the first time. The manufacturer tests each unit prior to shipment, so ignition should take place without failure. However, a number of small adjustments may be necessary to compensate for variations in gas pressure, altitude, and other factors particular to each installation.

VARIABLE OUTPUT CONTROL

The gas control valve is equipped with a variable output control. This control varies the rate of heat produced by the unit by varying the gas pressure to the main burner tube. A combination of heat output and the thermostat setting affect the length of the burn cycle. If your stove turns on and off too often, try, first, reducing the burn cycle by turning the HI/LOW knob, on the control valve, to a lower setting. Using the variable output control, the heat output of the unit can be reduced for mild fall and spring months, or maximized for the colder winter months. This adjustment can be made, by the homeowner, as necessary by turning the variable output control knob to “HI”, “LO” or any setting in between.

AIR SHUTTER

The air shutter is used to regulate the air-to-gas combustion mixture, which in turn influences the size and color of the flames. The air shutters have been positioned in the general location needed for the type of gas being used. If the stove is being converted for use with a different fuel, the air shutters will need repositioning. If the unit is not burning as well as it should, then the air

shutters may need adjusting. To adjust the air shutters, open the front left door and locate the shutter position indicator, as shown in Figure 10. Loosen the position indicator screw. The rod should be free to move. The open position (LP) is a counterclockwise rotation, and the closed position (NG) is a clockwise rotation. Carefully adjust the position of the shutter indicator to the desired location. Then tighten the set screw. Very little movement is needed to substantially change the burn and flame pattern.

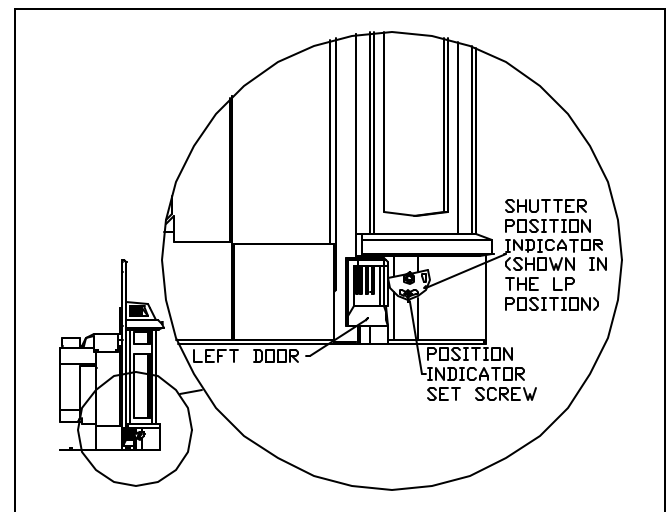

Figure 10: Air Shutter Adjustment

PILOT ADJUSTMENT

The pilot light is preset by the manufacturer and should not need adjustment. The pilot light flame should be large enough to engulf the thermopile and thermocouple located next to the pilot, but not so large as to create excessive noise or consume excessive gas. (*Refer to figure 11*) However, it can be adjusted by means of the pilot light adjustment screw located on the gas control valve. Open the valve door to access the pilot adjustment screw. Note that the pilot flame must engulf the thermopile so that the thermopile can generate sufficient milli-voltage (325 to 750-mv) to power the milli-volt gas control valve. The flame on the pilot should look like Figure 11.

Controlling the Windsor Bay by the wall-mounted thermostat may become erratic, nonexistent, or the unit may go out, if the pilot flame is too small or misdirected away from the thermopile.

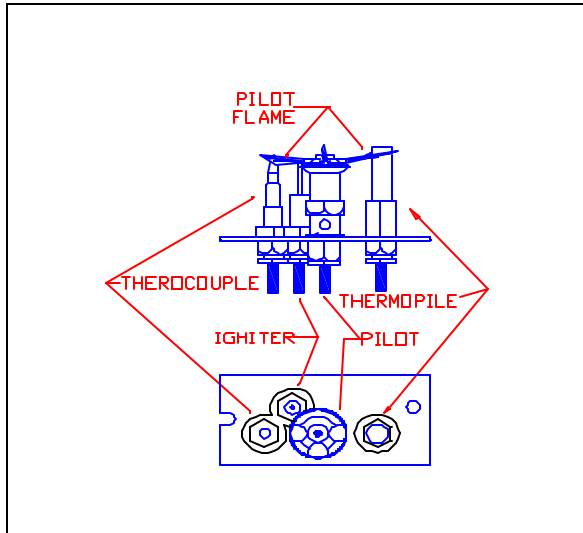

Figure 11: Pilot Adjustment

WARNING

The control has an interlock device. If the stove has been lit, it will not relight immediately. After shutting off all gas flow, the pilot burner cannot be relit until the thermocouple has cooled, allowing the electromagnet to be released (*Approx. 60 sec.*). The gas control knob is designed to be operated by hand. Do not use any tools during this operation.

BURNER FLAME APPEARANCE

Once the unit is lit, observe the flame pattern and adjust as necessary. Also, a periodic visual check of the burner flame should be performed. The burner flames can be adjusted by means of the air shutter. To determine if the burner flame needs adjustment, it is necessary to view the flame pattern with the variable output control knob at its highest setting (turn fully counter-clockwise). Allow the unit to operate for 10 minutes enabling the entire unit to reach

temperature and for the flame pattern to stabilize. The flame pattern should be similar to the one shown in Figure 12. There are several guidelines to aid in determining if the flame pattern is correct:

1. The flame should not be dirty, smoky, sooty, or lick the top of the stove.
2. The flame should not rise off of the burner tube, called "lifting".
3. Flames should not impinge heavily on the log set. They should "fit" through the pre-formed spaces designed in the log set.

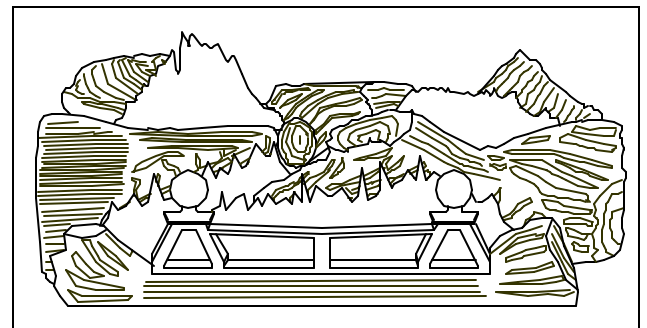

Figure 12: Burner Flame Appearance

Maintenance and Care

The Windsor Bay requires minimal routine maintenance and care. The unit should always be cool and off when being serviced.

WARNING: Do not substitute materials. For replacement parts, or for information about parts or service, contact your local HearthStone dealer.

NOTE: Label all wires prior to disconnection when servicing controls. Verify proper operation after servicing.

CLEANING

WARNING: DO NOT CLEAN THE UNIT WHEN IT'S HOT!

The unit should receive regular cleaning on, under, and around the stove to prevent the buildup of dust and lint. The exterior surfaces of the unit can be cleaned using soap, water, and a soft cloth. **Do not** use abrasive or chemical cleaners and take care not to scratch the glass or enamel finish (if so equipped) when cleaning the unit. The use of chemical or wax based cleaners or polishes is not recommended due to the potential for discoloration when the residue of the cleaners or polishes is exposed to heat.

FIREBOX

The firebox should receive periodic cleaning to prevent the accumulation of dust, lint, and other debris. To clean the firebox, set the thermostat to the "OFF" position and turn off the gas at the gas control valve. When the unit is cool, remove the front and carefully remove the decorative ceramic fiber log set (after it has cooled), taking care not to damage the logs or chip the enamel cast iron. Clean the firebox, burner tube, and pilot assembly and carefully vacuum the entire surface of the log set. Take care to

thoroughly vacuum the ports (holes) along the top of the burner tubes and the pilot assembly.

PILOT & BURNER FLAMES

With the decorative ceramic fiber logs out of the firebox, fasten the front shut and momentarily light the unit according to lighting instructions described in the How To Turn the Unit On & Off section of this manual. Check to ensure a flame is burning from each burner port. The pilot flame should be large enough to engulf the thermocouple and thermopile as shown in Figure 11.

NOTE: Do not operate the unit for more than 1-2 minutes without the log set in place. Turn the unit off by setting the thermostat to "OFF", and turning the gas control valve off. Allow the unit to cool.

Check and clean any burner ports that were not burning properly or at all. Clean burner ports using a soft brush or vacuum cleaner. If the pilot flame height needs adjustment it should be adjusted by a qualified service technician as described in the Initial Adjustments section of this manual.

Complete the cleaning procedure by carefully placing the log set within the firebox as described in the Log Set Information section of this manual. Fasten the front façade on. Turn on the gas, light the unit and check for proper operation. Flame patterns should look like Figure 12. Regularly check to insure the area around the Windsor Bay is kept free and clear from combustible materials, gasoline, and other flammable vapors and liquids. Check that the flow of combustion and ventilation air is not obstructed.

Once a year the unit and its venting system should be inspected by a qualified

service technician to ensure that it is clean, free of obstruction, safe, and in good working order. If service or maintenance is required, a qualified service technician should perform it.

CLEANING THE GLASS

If operating on propane, it may be necessary to clean the inside of the glass occasionally. Do not use abrasive cleaners, steel wool, or a razor blade. Scratching the glass will weaken the integrity of the glass. Your dealer will usually stock a gas fireplace

glass cleaner or a window cleaning fluid will work adequately. **Do not clean when hot!**

⚠ **WARNING:** Do not operate this appliance with the glass panel removed, cracked or broken. A licensed or qualified service technician should perform replacement of the glass assembly. Contact your authorized dealer for replacement glass.

NOTE: If the vent-air system is disassembled for any reason, re-install per the instructions provided in the Venting section of this manual.

Parts Lists

Part #	Description	Part #	Description
1841-402	2.625 x 3.5 SIDE STONE	5800-120	BLOWER DUCT (UPPER)
1841-401	9.375 X 2 FRONT STONE	5800-140	STONE CLIP-FRONT
1841-400	11.5/10.75 X 2.75 TOP STONE	5800-150	GLASS CLIP-FRONT & SIDE
2810-232	LEFT SIDE DOOR	5800-155	GLASS CLIP-SIDE
2810-234	RIGHT SIDE DOOR	5800-160	GLASS CLIP-FRONT
2810-510	FRONT	5800-170	STONE CLIP-SIDE
2810-640	FRONT GRILLE	5800-180	GRILLE CLIP-SIDE
2810-682	LEFT SIDE GRILLE	5800-200	ON/OFF/T' STAT SWITCH BRACKET
2810-684	RIGHT SIDE GRILLE	5800-210	SHUTTER POSITION INDICATOR PLATE
2810-690	TOP CENTER GRILLE	5800-220	SHUTTER CRANK ROD
28XX-732	LEFT SIDE-SMALL SURROUND	5800-230	SHUTTER LOCATOR ARM
28XX-734	RIGHT SIDE-SMALL SURROUND	5800-240	SHUTTER
28XX-736	TOP-SMALL SURROUND	5800-250	SHUTTER PACKING CLIP
28XX-742	LEFT SIDE-LARGE SURROUND	7211-235	BURNER TUBE-LEFT
28XX-744	RIGHT SIDE-LARGE SURROUND	7211-236	BURNER TUBE-RIGHT
28XX-746	TOP-LARGE SURROUND	7211-300	GAS VALVE
2810-824	HEAT EXCHANGER	7211-372	BURNER: PILOT, CON. TOP 4 WAY NG .62mm, SIT
2810-825	HEAT EXCHANGER BASE	7200-131	HOOD ORIFICE (NG) #46
5300-085	PILOT SHEILD	7211-136	SIT PILOT ORIFICE (LP) .35
5800-010	FIREBOX	7211-016	FLEX, 3/8" NPT MALE x 24" GAS TUBE
5800-020	VALVE BRACKET	7211-050	GAS MANIFOLD
5800-030	BURNER PAN LOG HOLDER/SECONDARY	3030-019	GLASS 3-3/4 x 11-9/16 x 0.5mm
5870-035	AIR PLENUM	7211-942	BLOWER ASSEMBLY
5870-040	AIR INLET PLENUM	5870-055	RESTRICTOR
5870-050	EXIT PLENUM	3030-018	GLASS 33-1/8 x 18-3/4 x 0.5mm
5870-060	LEFT BLOWER DUCT	3110-051	1/2 DOOR ROPE
5870-070	RIGHT BLOWER DUCT	3160-080	3/4 TAPE (GLASS) (FT)
5800-080	FIRE BAFFLE	3160-170	INTAKE GASKET 5.75" x 2.75"
5800-085	HEAT EXCH'R LIMITER (RIGHT)	3160-171	EXHAUST GASKET 4" x 3"
5800-090	HEAT EXCH'R LIMITER (LEFT)	3160-920	HEAT EXCHANGER GASKET 19-7/8 x 7-7/8 STG-D
5800-100	F'BOX TO SURROUND SHROUD	4700-0420	LOWER DOOR HINGE
5800-105	SHROUD BRACKET	7200-125	HOOD ORIFICE (LP) #56
7211-163	SIT PILOT ORIFICE (NG) .62	7211-541	LEFT, REAR LOG
98-56300	NG CONVERSION KIT	7211-542	RIGHT, REAR LOG
2421-341	ANDIRON	7211-543	LEFT, MIDDLE LOG
5870-120	EMBER SCREEN	7211-544	RIGHT, MIDDLE LOG
7211-505	CHARCOAL EMBERS, SMALL (4 oz.)	7211-545	FRONT LOG
7211-547	CHARCOAL, EMBERS, LARGE (2 oz.)	7211-546	TOP REAR LOG
98-56301	LP CONVERSION KIT		
5870-037	SUPPORT, ANDIRON	XX = Color	10 Matte, 20 Brown, 30 Almond, 66 Navy

› **WARNING:**

Do not substitute Materials. For replacement parts, or for information about parts or service, contact your authorized HearthStone retailer. For the name of the authorized retailer nearest to you, call (802) 888-5235 or write:

HearthStone Quality Home Heating Products
317 Stafford Ave. Morrisville, Vermont 05661
E-Mail: cservice@hearthstonestoves.com

TROUBLESHOOTING

Symptom	Possible Cause	Corrective Action
1. Pilot will not light.	A. Insufficient gas pressure, air in the pilot line, or dirty or kinked gas line.	A. Using the piezo sparker, try to light the pilot. If it will not light, check the inlet gas pressure.
	B. Pilot orifice plugged.	B. Clean or replace the pilot assembly.
	C. Defective or misaligned electrode at pilot.	C. If a match lights a pilot, check the electrode gap and location. Should be a 1/8" gap in the flame area.
	D. Defective ignitor.	D. Check for a good connection between ignitor and electrode. Check wire insulation. If properly connected and no spark, replace ignitor.
	E. After sitting for "off" season (summer), pilot assembly may be dirty.	E. Clean or replace the pilot assembly.
2. Pilot will not stay lit after carefully following lighting instructions.	A. Low or too high gas pressure	A. Check for proper inlet pressure for the gas being used.
	B. Faulty connections.	B. Measure voltage between valve body and solder connection on the rear of the valve (where the blue wire connects). It should be no less than 7 mV.
	C. Defective thermocouple.	C1. Ensure that the thermocouple connection at the gas valve is tight. C2. Check thermocouple output using milli-volt meter. Disconnect from valve and read voltage across wire ends. If the reading is less than 15 mV, replace the pilot assembly. C3. If burning NG, check pilot flame to see that it is impinging on the top of the thermocouple. Clean or replace pilot for maximum flame impingement.
	D. Pilot dirty or plugged.	D. Clean or replace the pilot assembly.

TROUBLESHOOTING (CONT.)

Symptom	Possible Cause	Corrective Action
3. Pilot burning, no gas to main burner, valve knob in the "ON" position, thermostat and/or on/off/t'stat switch in the "ON" position.	A. Thermostat switch or wires defective.	A. Check thermostat/wiring for proper connections. Place jumper wire across terminals at thermostat. If burner comes on, replace defective thermostat. If not OK, place jumper across thermostat wires at gas valve. If burner comes on, tighten connections, or replace faulty wires.
	B. Thermopile may not be generating sufficient voltage.	B. Check thermopile output, using a milli-volt meter. If the optional on/off kit has not been installed, take the readings across generator terminals of the gas valve. TPTH and TP). With the on/off kit, take the readings across TH and Terminal block (which corresponds to #3 on the switch). Milli-volt reading should be greater than 325 mV. If not, replace the pilot assembly. If the meter reading is OK, but the burner does not come on, replace the gas valve.
	C. Plugged burner orifice.	C. Remove and check burner orifice, clean or replace. Note: do not use any metal cleaning device, as this may damage the orifice.
4. Pilot and burner come on, but go out after some warm-up.	A. Inconsistent, of insufficient flame on thermopile.	A. Adjust pilot flame size and assure that the flame is aimed directly at the thermopile.
	B. Insufficient gas pressure.	B. Check line pressure to ensure that the correct inlet pressure is present for the type of gas being used. If propane pressure is inconsistent, check for water condensation at the regulator.
5. Frequent pilot outage problem.	A. Pilot flame may be too low or blowing, (high), causing the pilot safety to drop out.	A. Clean and/or adjust the pilot flame for maximum impingement on the thermopile and thermocouple.
6. Glass fogs	A. A normal result of gas combustion.	A. After the heater has warmed up, the glass should clear.
7. Blue Flames	A. A normal result during the first 20 minutes.	A. Flames should begin to turn more yellowish after 20 minutes of burning.
		B. If the blue color stays, adjust the air shutter for a proper burn.

TROUBLESHOOTING (CONT.)

Symptom	Possible Cause	Corrective Action
8. Floating flames, lazy ill-defined, quiet flames which roll around, sometimes completely off of the port, sometimes with overly yellow tips. Possible sooting. Usually accompanied by the odor of aldehydes.	A. Potentially dangerous incomplete combustion due to incorrect air to fuel ratio (lack of combustion air or excessive fuel delivery I.e. excessive gas pressure, overrating of appliance).	A. Check the appliance input rate and reduce if necessary. The air intake/exhaust flow system may be too restrictive or blocked (the rate at which the exhaust leaves [draft] determines the rate at which the combustion air is delivered). Poor draft results in insufficient air delivery or a restricted exhaust. Correct air intake/exhaust flow system.
	B. Incorrect air intake/exhaust flow system. Causes may be: B1. Blocked Burner. B2. Blocked primary air. B3 Blocked secondary air inlets.	B1. Clear ports. B2. Clear obstructions. B3. Clear obstructions. Note: If gas pressures are correct and the flames stay the same, adjust the air shutter for a proper burn.
9. Burner flashback. Air-gas mixture ignites inside the burner near the orifice, usually creating a roaring noise like a blow torch. The problem is an imbalance of gas flow velocity and burning speed pattern.	A. Excessive draft.	A. Adjust the air shutter for a proper burn.
	B. Burner input underrated.	B. Check input rate. Check input pressure using a manometer. Confirm correct gas pressure at house meter or tank (call gas company). Confirm burner orifice size.
	C. Valve leak if flashback occurs with burner valve in off position	C. Replace valve. If above corrections do not eliminate flashback, replace burner.
	D. Improper gas pipe size.	D. Correct plumbing.

TROUBLESHOOTING (CONT.)

Symptom	Possible Cause	Corrective Action
10. Delayed ignition (makes a sudden "whoosh" noise as the burner lights). This is a buildup of gas's prior to ignition. This is more prevalent with propane (LP) fuel.	A. Incorrect air-to-fuel ratio. A1. Primary air incorrect. A2. Burner ports plugged.	A1. Adjust the air shutter for a proper burn. A2. Open ports to allow for proper travel of flames.
	B. Improper log placement.	B. Reposition logs to eliminate interference with flame travel.

HEARTHSTONE GAS-FIRED STOVE AND INSERT LIMITED WARRANTIES

These warranties give you specific legal rights. You may also have other rights which vary from State to State.

HearthStone Quality Home Heating Products, Inc. (HearthStone) warrants **to the original purchaser only** (the “Original Purchaser”) the new gas-fired stove/insert manufactured by HearthStone and purchased by the Original Purchaser (referred to as the “Stove” for simplicity) against any of the occurrences listed in this document that result from defects in material or workmanship. All obligations of HearthStone under this document commence on the date the Original Purchaser purchases the Stove (the “Purchase Date”).

LIMITED LIFETIME WARRANTY

HearthStone warrants the following parts of the Stove against the following occurrences that result from defects in material and workmanship:

- All cast iron parts, including the cast iron heat exchanger – against breakage, cracking or burn-through.
- All stones – against cracking or breakage due to thermal stress, **excluding** surface and hairline cracks and scratches that do not affect the operation or safety of the Stove.
- Glass – against breakage due to thermal shock.

LIMITED FIVE-YEAR WARRANTY

HearthStone warrants the following parts of the Stove against the following occurrences that result from defects in material and workmanship:

- Firebox and firebox baffle – against breakage, cracking or burn-through.
- Convective heat exchanger – against breakage, cracking or burn-through.
- Burners, air shutters and orifices – against breakage, cracking or burn-through.
- Ceramic logs and embers – against breakage, cracking or burn-through.

This warranty expires on the fifth (5th) anniversary of the Purchase Date.

LIMITED THREE-YEAR WARRANTY

HearthStone warrants the following parts of the Stove against the following occurrences that result from defects in material and workmanship:

- Gas train, including gas valve, millivolt wiring, spill switch, pilot assembly, thermopile, thermocouple, piezo igniter, and, if the Stove is a vent-free model, ODS system – against breakage or malfunction.

This warranty expires on the third (3rd) anniversary of the Purchase Date.

LIMITED ONE-YEAR WARRANTY

HearthStone warrants the following parts of the Stove against the following occurrences that result from defects in material and workmanship:

- Enamel Finish – against peeling or fading, **excluding** chipping, mechanical abrasion, chemical abrasion or crazing.
- Gaskets and sealants – against breakage or deterioration.
- Accessories and electrical components such as blowers, switches and thermo discs, **excluding** venting components, hearth components, electrical components and other components or accessories used in conjunction with the installation of the Stove **not** manufactured or supplied by HearthStone – against breakage or malfunction.

This warranty expires on the first (1st) anniversary of the Purchase Date.

EXCLUSIONS

The warranties contained in this document do not cover, nor is HearthStone responsible for:

1. Damage resulting from installation or operation of the Stove in a manner contrary to the owner's manual.
2. Damage or non-performance resulting from faulty or incomplete setup, installation and start-up or mishandling, abuse, or misuse of the Stove, including but not limited to over-firing.
3. Damage resulting from installation, modification, alteration, repair or service of the Stove by any party other than HearthStone or an authorized HearthStone dealer (a "Dealer").
4. Damage due to water or due to installation of the Stove in a damp or high condensation area.
5. Damage due to installation of the Stove in an atmosphere contaminated by damaging chemicals, including but not limited to chlorine, fluorine or salts.
6. Scratches on glass, enameled surfaces or stones due to mechanical abrasion.
7. Standard wear and tear of the Stove resulting from normal usage over time.
8. Damage, operational-related problems, or inadequate performance caused by site, installation or environmental conditions beyond HearthStone's control, including but not limited to nearby trees, rooftops, buildings, wind, hills, mountains, inadequate or excessive venting, insufficient make up air, or negative air pressure whether or not caused by mechanical systems such as furnaces, exhaust fans, clothes dryers, etc.
9. A defect in any part of the Stove if the Original Purchaser fails to comply with HearthStone's or a Dealer's request to ship the part or the Stove to HearthStone or a Dealer, as the case may be.

THE WARRANTIES CONTAINED IN THIS DOCUMENT ARE EXCLUSIVE AND ARE GIVEN BY HEARTHSTONE AND ACCEPTED BY THE ORIGINAL PURCHASER IN LIEU OF ALL OTHER EXPRESS WARRANTIES AND ANY OBLIGATIONS, LIABILITIES, RIGHTS, CLAIMS, OR REMEDIES IN CONTRACT OR TORT, WHETHER OR NOT ARISING FROM HEARTHSTONE'S NEGLIGENCE, ACTUAL OR IMPUTED. ALL IMPLIED WARRANTIES, INCLUDING THE WARRANTIES OF MERCHANTABILITY AND FITNESS FOR A PARTICULAR PURPOSE, ARE GIVEN **ONLY** TO THE EXTENT REQUIRED BY FEDERAL OR STATE LAW. EXCEPT AS OTHERWISE REQUIRED BY STATE LAW, UPON THE EXPIRATION OF THE EXPRESS LIMITED WARRANTIES CONTAINED HEREIN, **NO** IMPLIED WARRANTIES, INCLUDING THE IMPLIED WARRANTIES OF MERCHANTABILITY OR FITNESS FOR A PARTICULAR PURPOSE, SHALL APPLY TO THE SUBJECT STOVE. **SOME STATES DO NOT ALLOW LIMITATIONS ON HOW LONG AN IMPLIED WARRANTY LASTS, SO THE ABOVE LIMITATION MAY NOT APPLY TO YOU.**

THE WARRANTIES CONTAINED IN THIS DOCUMENT EXTEND **ONLY** TO THE ORIGINAL PURCHASER OF THE STOVE WARRANTED HEREUNDER. THEY DO NOT EXTEND TO ANY SUBSEQUENT OWNERS.

UNDER NO CIRCUMSTANCES SHALL HEARTHSTONE BE LIABLE TO THE ORIGINAL PURCHASER OR ANY OTHER PERSON FOR ANY INCIDENTAL OR CONSEQUENTIAL DAMAGES, INCLUDING BUT NOT LIMITED TO DAMAGE TO PROPERTY OR PERSONAL INJURIES, WHETHER ARISING OUT OF BREACH OF WARRANTY, TORT, OR OTHERWISE, EVEN IF HEARTHSTONE HAS BEEN APPRAISED OF THE POSSIBILITY OF SUCH DAMAGES. **SOME STATES DO NOT ALLOW THE EXCLUSION OR LIMITATION OF INCIDENTAL OR CONSEQUENTIAL DAMAGES, SO THE ABOVE LIMITATION OR EXCLUSION MAY NOT APPLY TO YOU.**

QUALIFYING FOR WARRANTY COVERAGE

To obtain performance of any obligation under this document, the Original Purchaser must, **within the applicable warranty time period**, contact HearthStone, at the address listed in the Warranty Registration section below or at **(802) 888-5235**, or a Dealer for instructions regarding the return of defective parts for repair, the return of the Woodstove for repair, or a Dealer service call. The Original Purchaser should refer to the Dealer network search engine contained on HearthStone's Web site (www.hearthstonestoves.com), or call HearthStone at (802) 888-5235, to find a Dealer nearest the Original Purchaser's location.

REMEDY

The remedy for any breach of the foregoing warranties will consist of repair or replacement, at HearthStone's option, of any covered defect in the Stove. When the Original Purchaser contacts HearthStone or a Dealer, HearthStone or the Dealer, as the case may be, will instruct the Original Purchaser to **either** return the defective part, or the entire Stove (if needed), with shipping prepaid, to HearthStone or a Dealer **or** allow a Dealer to make a service call at the place where the Stove is located. In the event the Original Purchaser refuses to allow a Dealer to make a service call, HearthStone or a Dealer, as the case may be, will request that the Original Owner return the defective part, or the entire Stove (if needed), with shipping prepaid, to HearthStone or a Dealer. **Notwithstanding any other provision of this document, the Original Purchaser shall pay for any travel fees and service charges related to a Dealer's service call.**

Parts: HearthStone will replace defective parts covered by the foregoing warranties at no charge.

Labor: Within the first (1st) year after the Purchase Date, HearthStone will pay for warranty labor performed by a Dealer at HearthStone's published labor rates in effect at the time the labor is performed. Thereafter, the Original Purchaser is responsible for the cost of labor.

Shipping cost for parts: Within the first ninety (90) days after the Purchase Date, HearthStone will pay for the shipping of Stove parts covered by any of the foregoing warranties to and from HearthStone or a Dealer, as the case may be. Thereafter, the Original Purchaser is responsible for all shipping costs related to shipping Stove parts to and from HearthStone or a Dealer, as the case may be.

Shipping cost for the Stove: Within the first (1st) year after the Purchase Date, if the Original Purchaser is instructed to return the Stove to HearthStone or a Dealer for repair, HearthStone will pay fifty percent (50%) and the Original Purchaser will pay fifty percent (50%) of the shipping costs related to shipping the Stove to and from HearthStone or a Dealer, as the case may be. Thereafter, the Original Purchaser is responsible for one hundred percent (100%) of all of the shipping costs related to shipping the Stove to and from HearthStone or a Dealer, as the case may be. Notwithstanding any other provision of this document, in no event will HearthStone pay for any Dealer fees or other fees for pick up or delivery of the Stove returned for repair; the Original Purchaser shall be responsible for any such fees.

WARRANTY REGISTRATION

The Original Purchaser may send a completed and signed Warranty Registration Form, which is enclosed in the Stove warranty packet, to the following address:

**HearthStone Quality Home Heating Products, Inc.
Warranty Department
317 Stafford Avenue
Morrisville, VT 05661**

NOTE: SENDING IN THE SIGNED WARRANTY REGISTRATION FORM IS NOT A CONDITION OF WARRANTY COVERAGE OR HEARTHSTONE'S PERFORMANCE.